

The **BA317E** is a third generation intrinsically safe tachometer that has similar functions as the BA318E, but is housed in a smaller 96 x 48mm DIN enclosure. The tachometer is easy to use and can be configured on-site to operate with a magnetic pick-off, switch contact, proximity detector, open collector or voltage pulse sensor. A slide-in scale card simplifies identification and international intrinsic safety certification permits worldwide installation.

Main application of the BA317E is to measure and display rotational speed within a hazardous area. To assist with routine maintenance the BA317E tachometer also includes a run-time clock that records the number of hours that the monitored machinery has been operating.

The display has high contrast and a wide viewing angle, allowing the tachometer to be read in most lighting conditions over a wide temperature range. Speed may be displayed in almost any units of measurement per second, minute or hour. Run-time is shown on the lower display in hours with a tenth of an hour resolution. If not required, the run-time display may be disabled.

IP66 front panel protection with a neoprene gasket to seal the joint between the tachometer and the instrument panel allows the BA317E to be installed in areas that will be washed down. To simplify installation and maintenance, the tachometer has removable terminal blocks enabling panel wiring to be completed before the instrument is installed.

International intrinsic safety certification permits the BA317E tachometer to be installed worldwide. When configured to operate with a sensor having a voltage or magnetic pick-off output, the input terminals comply with the requirements for *simple apparatus* reducing system design and documentation.

Display backlighting which is internally powered from the tachometer is available as a factory fitted option. It provides green background illumination enhancing daylight viewing and allowing the display to be easily read at night or when installed in a poorly illuminated area.

One of the following three optional outputs may be factory fitted to the BA317E tachometer. All are isolated and have been certified as separate intrinsically safe circuits complying with the requirements for *simple apparatus*.

Optional isolated pulse output synchronously retransmits the tachometer input pulse to other instruments. The output pulse frequency may be divided and the pulse width may be defined.

Optional isolated 4/20mA output may be configured to produce an analogue output proportional to any part of the speed display.

Optional dual alarms which can switch hazardous area loads such as a sounder or solenoid valve, or safe area loads via a Zener barrier or isolator. The two galvanically isolated, solid state voltage free outputs may be independently conditioned as speed or run-time alarms with normally open or closed outputs. Annunciators on the BA317E display show the status of both alarm outputs.

Rugged versions and a larger display are available in other models within the range. The BA317E-SS is identical to the BA317E except that it is housed in a rugged stainless steel enclosure with a 10mm thick window that may be installed in an Ex e or Ex p panel enclosure without invalidating the enclosure's certification. The BA317NE has Ex nA certification allowing installation in Zone 2 or 22 without Zener barriers or galvanic isolators.

If a larger display is required, the BA318E offers similar features in a 144 x 72mm enclosure.

BA317E

One input tachometer

Intrinsically safe for use in all gas hazardous areas

◆ **Configurable input:** magnetic pick-off, switch contact, proximity detector, open collector or voltage pulse.

◆ **Separate speed and run-time displays.**

◆ **Intrinsically safe**

◆ **96 x 48mm DIN enclosure with IP66 front protection.**

◆ **Optional:** Backlight dual alarms or 4/20mA output or pulse output

◆ **3 year guarantee**



BEKA associates

Sales & Support Distributor:- Stockshed Limited. Stonecroft House, Mud Lane, Eversley. Hampshire. RG27 0QS. U.K. Tel. (0118) 9734955 e-mail info@stockshed.com

SPECIFICATION

Power supply		
Voltage	10 to 28V from a Zener barrier or galvanic isolator	
Current	16mA max plus 22.5mA for optional backlight	
Input		
	Lower	Upper switching thresholds
Switch contact	100Ω	1kΩ
Proximity detector (NAMUR)	1.2mA	2.1mA
Open collector	2kΩ	10kΩ
Magnetic pick-off	0	+40mV
Voltage pulse (low)	1V	3V 28V max
Voltage pulse (high)	3V	10V 28V max
Frequency		
Switch contact	150Hz typical] Depends upon pulse width and debounce setting.
Other inputs	100kHz max	
All inputs	0.01Hz min	
Display		
Type	Liquid crystal	
Zero blanking	Blanked apart from 0 in front of decimal point	
Speed	8 digits 9mm high	
Decimal point	1 of 7 positions or absent	
Run-time	6 digits 6mm high, 99999.9 hours max	
Grand total run-time	5 x 10 ⁶ hours max	
Remote reset		
	Contact closure with resistance less than 10kΩ	
Configurable functions		
Speed scale factor	Adjustable between 0.0001 and 99999 input pulses / revolution.	
Speed timebase	Speed may be displayed per second, minute or hour.	
Intrinsic safety		
Europe ATEX Code	Group II Category 1G Ex ia IIC T5 Ga	
Cert. No.	-40°C ≤ Ta ≤ 70°C ITS16ATEX28408X	
International IECEx Code	Ex ia IIC T5 Ga	
Cert. No.	-40°C ≤ Ta ≤ 70°C IECEx ITS 16.0004X	
ETL & cETL Code	Class I Div 1 Gp A, B, C, D T5 (USA & Canada) Class II Div 1 Gp E, F, G. Class III Div 1 (USA & Canada) Class I Zone 0 AEx ia IIC T5 Ga (USA) Ex ia IIC T5 Ga (Canada) -40°C ≤ Ta ≤ 70°C	
Nonincendive USA & Canada ETL & cETL		
Code	Class I Div 2 Gp A, B, C, D T5 Class II Div 2 Gp F, G. Class III Div 2 -40°C ≤ Ta ≤ 70°C	
ETL Control No.	4008610	
Environmental		
Operating temp	-40 to +70°C display -20 to +70°C	
Storage temp	-40 to +85°C	
Humidity	to 95% at 40°C non condensing	
Vibration	Report available	
Enclosure	Noryl SE1GFN3. Front IP66, rear IP20	
EMC	Complies with EMC Directive 2014/30/EU	
Mechanical		
Terminals	Screw clamp for 0.5 to 1.5mm ² cable, removable terminal blocks.	
Weight	0.15kg	
Accessories		
Backlight	Green LED internally powered	
Scale card	Blank card fitted to all instruments. Can be supplied typeset with specified units of measurement for no additional charge at time of tachometer purchase. ~	
Tag legend	Specified tag number or application printed onto rear of instrument. ~	
One of the following three output accessories may be factory fitted to each tachometer. All have isolated outputs which have been certified as separate intrinsically safe circuits and comply with the requirements for <i>simple apparatus</i> .		
Pulse output	Isolated open collector	
Frequency	5kHz max, synchronous with input pulse or divisible.	
Divisible by	1, 10, 100, 1000 or 10000	
Pulse width	0.1, 0.5, 1, 2.5, 5, 10, 25, 50, 100, 250 or 500ms	
Ron	51Ω + 3V max	
Roff	1MΩ min	
I max	10mA	
4/20mA output	Isolated current sink.	
Voltage drop	5 to 28V	

DIMENSIONS (mm)

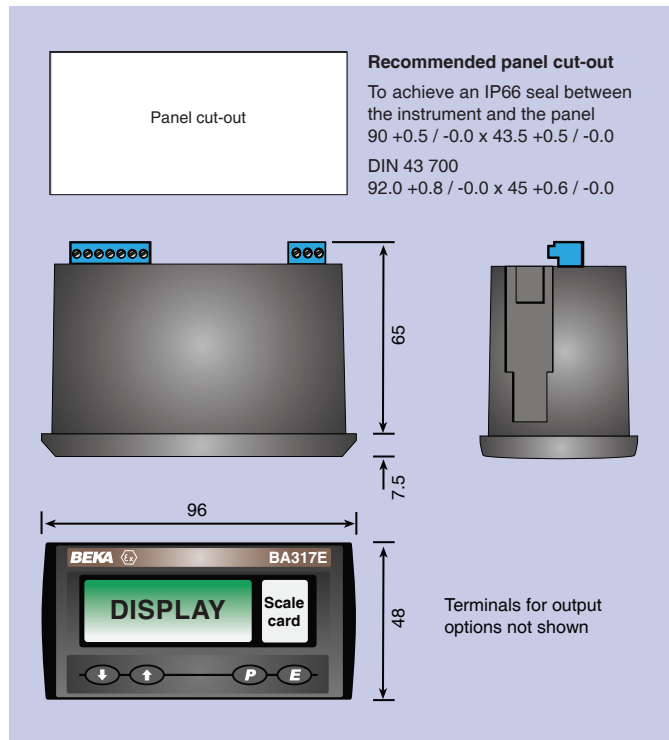

TERMINAL CONNECTIONS

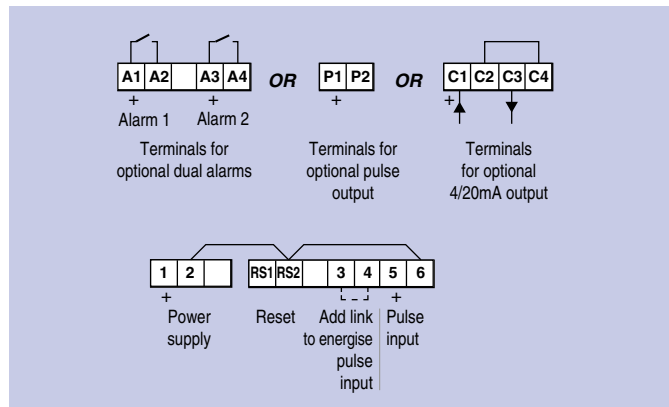

Alarms

Two alarms each of which may be independently configured as a speed or run-time, high or low alarm with a NO or NC output.

Outputs

Ron
Roff

Isolated single pole, voltage free solid state switch
5Ω + 0.7V max
1MΩ min

~ See accessory datasheet for details

HOW TO ORDER

Model number	Please specify BA317E
Input	Type *
Speed scale factor	XXXXX *
Speed timebase	Seconds, minutes or hours*
Accessories	Please specify if required
Display backlight	Backlight
Scale card	Legend required
	<i>No charge if ordered with tachometer.</i>
Tag	Legend required
One of following three output options:	
Pulse output	Direct retransmission or scaled*
or 4/20mA output	4/20mA output
or Dual alarms	Alarms

* Tachometer can be supplied configured as required for no additional charge. If configuration information is not supplied, instrument will be configured for open collector input with speed scaling factor of 1.0 and a timebase of minutes. Can easily be reconfigured on-site.