

Data Sheet

SonoMeter 31

Energy Meters

Description



MID examination certificate no.: LT-1621-MI004-023

The Danfoss SonoMeter 31 is a range of ultrasonic, compact energy meters intended for measuring energy consumption in heating and cooling applications for billing purposes. The meters are designed for remote meter read-out (AMR).

SonoMeter 31 energy meters consist of an ultrasonic flow sensor, a pair of Pt500 temperature sensors and a calculator with integrated circuits for temperature measurement, flow calculation and energy calculation.

Features

- Available in nominal flow rates qp 25, 40 and 60 m³/h
- DN65, DN80 and DN100 housings with flange connections
- MID approval for ultrasonic energy meter with dynamic range of 1:100 (qi:qp) in class 2
- Optional MID approved dynamic range of 1:250 (qi:qp) in class 2
- Temperature range 5–130 °C
- Short overload temperature up to 150 °C
- Operating pressure 25 bar as standard
- For 2 or 4 wire temperature sensors
- Glycol mixtures as option (not MID certified)
- Calculator with IP65 protection class as standard
- Flow sensor with IP65 protection class as standard (IP67 for combine heating and cooling applications)
- Return or supply pipe installation, for vertical or horizontal mounting
- Battery lifetime for at least 10 years
- Insensitive to dirt
- Remote reading via wired M-Bus, radio OMS 868 MHz, RS-485 Modbus RTU, pulse output, analog output and optical interface
- Two pulse inputs as standard (passive or active)
- Special option with 2 flow sensors, 2 pressure sensors and 3 temperature sensors measurement

Ordering

Energy meter application	Nominal flow, size and connection type	Comm. module	Energy unit	Installation	Power supply	Operating pressure	Code no.
Heating	DN65 / qp 25 m ³ /h / 300mm flange	M-Bus	MWh (2 dig.)	Return	battery 3.6V DC	25 bar	187F3300
Heating	DN65 / qp 25 m ³ /h / 300mm flange	OMS 868.95	MWh (2 dig.)	Return	battery 3.6V DC	25 bar	187F3301
Heating	DN65 / qp 25 m ³ /h / 300mm flange	M-Bus	MWh (2 dig.)	Return	mains 230V AC	25 bar	187F3302
Heating	DN65 / qp 25 m ³ /h / 300mm flange	OMS 868.95	MWh (2 dig.)	Return	mains 230V AC	25 bar	187F3303
Heating / cooling	DN65 / qp 25 m ³ /h / 300mm flange	M-Bus	MWh (2 dig.)	Return	battery 3.6V DC	25 bar	187F3304
Heating / cooling	DN65 / qp 25 m ³ /h / 300mm flange	OMS 868.95	MWh (2 dig.)	Return	battery 3.6V DC	25 bar	187F3305
Heating / cooling	DN65 / qp 25 m ³ /h / 300mm flange	M-Bus	MWh (2 dig.)	Return	mains 230V AC	25 bar	187F3306
Heating / cooling	DN65 / qp 25 m ³ /h / 300mm flange	OMS 868.95	MWh (2 dig.)	Return	mains 230V AC	25 bar	187F3307
Heating	DN80 / qp 40 m ³ /h / 350mm flange	M-Bus	MWh (2 dig.)	Return	battery 3.6V DC	25 bar	187F3308
Heating	DN80 / qp 40 m ³ /h / 350mm flange	OMS 868.95	MWh (2 dig.)	Return	battery 3.6V DC	25 bar	187F3309
Heating	DN80 / qp 40 m ³ /h / 350mm flange	M-Bus	MWh (2 dig.)	Return	mains 230V AC	25 bar	187F3310
Heating	DN80 / qp 40 m ³ /h / 350mm flange	OMS 868.95	MWh (2 dig.)	Return	mains 230V AC	25 bar	187F3311
Heating / cooling	DN80 / qp 40 m ³ /h / 350mm flange	M-Bus	MWh (2 dig.)	Return	battery 3.6V DC	25 bar	187F3312
Heating / cooling	DN80 / qp 40 m ³ /h / 350mm flange	OMS 868.95	MWh (2 dig.)	Return	battery 3.6V DC	25 bar	187F3313
Heating / cooling	DN80 / qp 40 m ³ /h / 350mm flange	M-Bus	MWh (2 dig.)	Return	mains 230V AC	25 bar	187F3314
Heating / cooling	DN80 / qp 40 m ³ /h / 350mm flange	OMS 868.95	MWh (2 dig.)	Return	mains 230V AC	25 bar	187F3315
Heating	DN100 / qp 60 m ³ /h / 350mm flange	M-Bus	MWh (2 dig.)	Return	battery 3.6V DC	25 bar	187F3316
Heating	DN100 / qp 60 m ³ /h / 350mm flange	OMS 868.95	MWh (2 dig.)	Return	battery 3.6V DC	25 bar	187F3317
Heating	DN100 / qp 60 m ³ /h / 350mm flange	M-Bus	MWh (2 dig.)	Return	mains 230V AC	25 bar	187F3318
Heating	DN100 / qp 60 m ³ /h / 350mm flange	OMS 868.95	MWh (2 dig.)	Return	mains 230V AC	25 bar	187F3319
Heating / cooling	DN100 / qp 60 m ³ /h / 350mm flange	M-Bus	MWh (2 dig.)	Return	battery 3.6V DC	25 bar	187F3320
Heating / cooling	DN100 / qp 60 m ³ /h / 350mm flange	OMS 868.95	MWh (2 dig.)	Return	battery 3.6V DC	25 bar	187F3321
Heating / cooling	DN100 / qp 60 m ³ /h / 350mm flange	M-Bus	MWh (2 dig.)	Return	mains 230V AC	25 bar	187F3322
Heating / cooling	DN100 / qp 60 m ³ /h / 350mm flange	OMS 868.95	MWh (2 dig.)	Return	mains 230V AC	25 bar	187F3323

Cable length of temperature sensors is 3.0m.

Cable length between flow sensor and energy calculator is 3.0m.

Accessories

Product	Designation	Quantity	Code no.
Power supply	Battery 3.6 V DC (D cell)	1 pc.	187F3380
Power supply	Mains unit 230 V AC	1 pc.	187F3381
Communication module	M-Bus module	1 pc.	187F3382
Communication module	Radio OMS 868.95 MHz	1 pc.	187F3383
Communication module	RS-485 Modbus RTU	1 pc.	187F3384
Communication module	RS-232 M-Bus	1 pc.	187F3385
Communication module	RS-485 M-Bus ¹⁾	1 pc.	187F3386
Communication module	M-Bus, RS232 and two pulses outputs ¹⁾	1 pc.	187F3387
Communication module	M-Bus, RS232 and two 4-20mA outputs ¹⁾	1 pc.	187F3388
Temperature sensor	Pt 500 / f 5.2 mm / 1.5 m cable, MID	1 pair	187F3125
Temperature sensor	Pt 500 / f 5.2 mm / 2 m cable, MID	1 pair	187F3126
Temperature sensor	Pt 500 / f 5.2 mm / 3 m cable, MID	1 pair	187F3127
Temperature sensor	Pt 500 / f 5.2 mm / 5 m cable, MID	1 pair	187F3390
Temperature sensor	Pt 500 / f 5.2 mm / 10 m cable, MID	1 pair	187F3391
Sensor pockets	Ø 5.2 mm, brass, 35 mm length	1 pair	087G6053
Sensor pockets	Ø 5.2 mm, brass, 52 mm length	1 pair	087G6054
Sensor pockets	Ø 5.2 mm, brass, 85 mm length	1 pair	087G6055
Sensor pockets	Ø 5.2 mm, brass, 120 mm length	1 pair	087G6056
Sensor pockets	Ø 5.2 mm, stainless steel, 85 mm length	1 pair	087G6057
Sensor pockets	Ø 5.2 mm, stainless steel, 120 mm length	1 pair	087G6058
Sensor pockets	Ø 5.2 mm, stainless steel, 155 mm length	1 pair	087G6059
Sensor pockets	Ø 5.2 mm, stainless steel, 210 mm length	1 pair	087G6060

¹⁾ Only with mains supply 230 V AC

Technical specifications

Diameter	DN65	DN80	DN100
Connection type	flange		
Overall length, mm	300	350	350
Flow rate:			
• Nominal, m ³ /h	25	40	60
• Maximum, m ³ /h	50	80	120
• Standard min., m ³ /h	0.25	0.4	0.6
• Starting, m ³ /h	0.10	0.16	0.24
Max. operating pressure	25 bar		
Flow sensor temp. range	5 to 130 °C (short overload up to 150 °C)		
Flow sensor cable length	3,0 m		
Medium	Water quality with pH 7 to 9.5		
Pressure loss at q _p , mbar	200	180	180
Measuring cycles	Volume every 1 sec., energy, temperature sensors and display update every 10 sec.		
Temperature sensors	Pt 500 ø 5.2 mm with 2-wire leads		
Temp. sensor cable length	3,0 m		
Max. temp. diff. (Δθ _{max})	150 K		
Min. temp. diff. (Δθ _{min})	3.0 K		
Starting temp. diff. (Δθ)	0.15 K		
Temp. measuring range	0 to 180 °C		
Supply voltage	3.6 V DC Lithium-battery (D-cell) or Mains supply 230V AC		
Battery life time	min. 10 years (including AMR communication)		
Approval	EN1434 class 2		
Environmental class	EN1434 class C		
Ambient class	class E2 + M1		
Protection class	Calculator: IP 65; Flow sensor: IP 65 (IP67 for heat and cooling meter)		
Ambient operating temp.	Calculator: 5 to 55 °C; Flow sensor: -30 to 55 °C		
Ambient storage and transportation temp.	5 to 55 °C		
Max. ambient humidity	93% rel. humidity		
Display	LCD, 8-digit		
Display units	MWh - kWh - GJ - Gcal - °C - m ³ - m ³ /h		
Display values	Energy - volume - flow rate - power - temperatures		

Application drawings

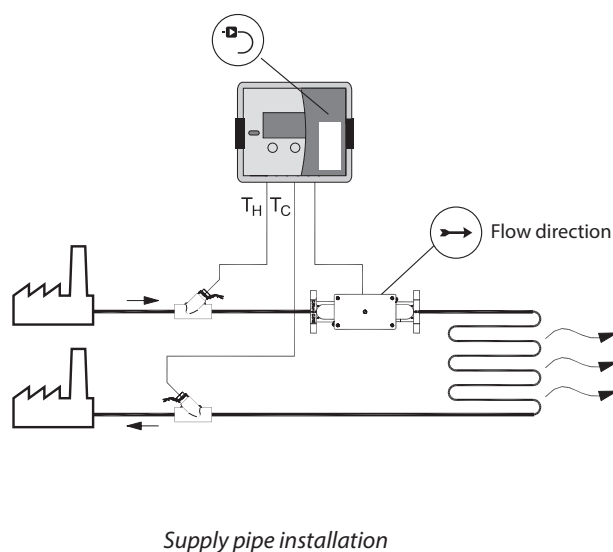
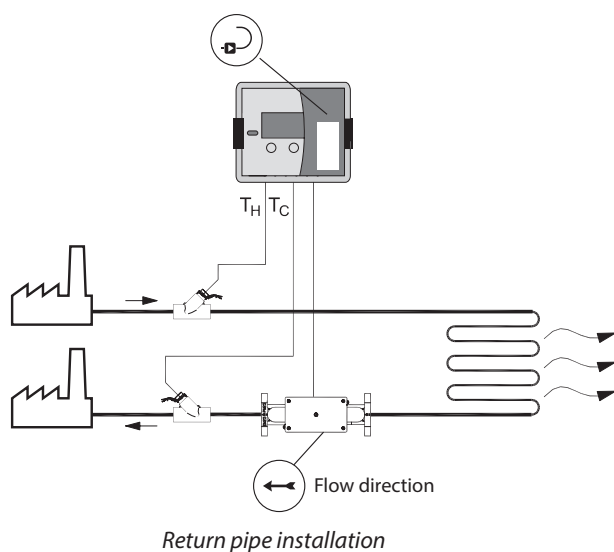

Accuracy

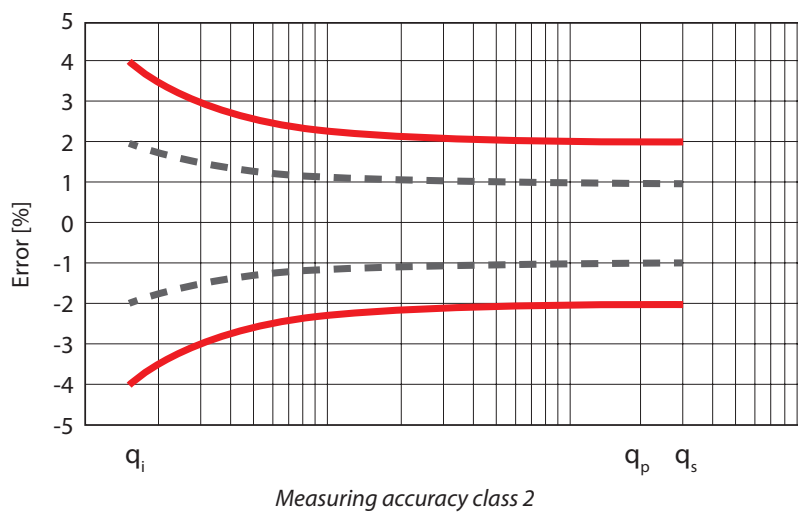

Pressure loss

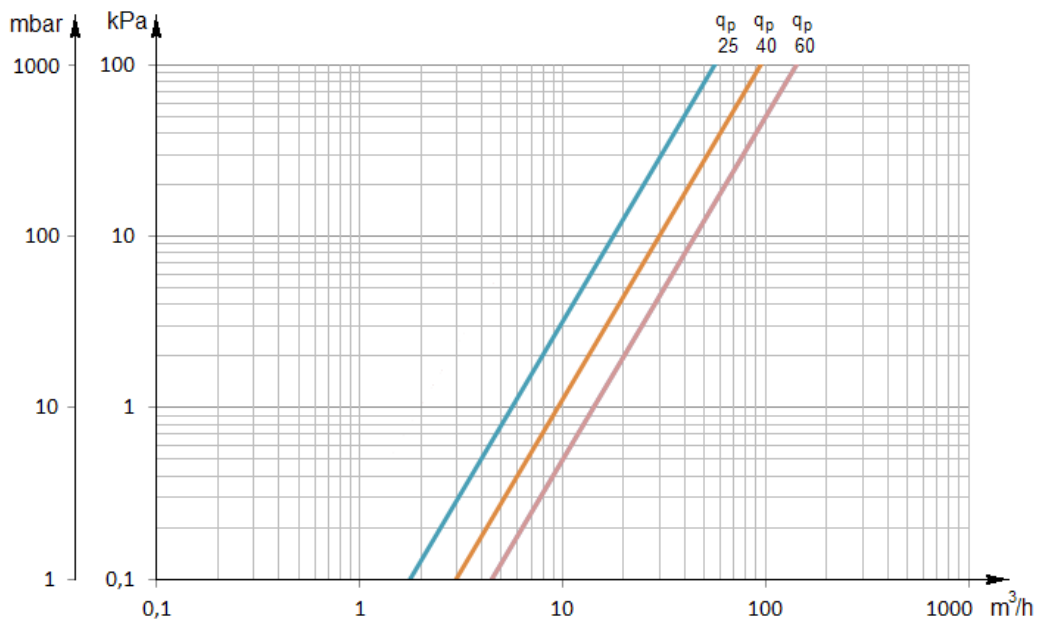

Design and function

Optical interface

Optical interface is integrated into the front panel of the calculator. It is designed for data reading via M-bus protocol.

The optical interface is activated by pressing the control button and shuts automatically off 5 minutes after the last pressing button or after completing data transmission via interface.

Wired M-Bus interface

The energy meter has 1 slot for an additional communication module. The internal M-Bus module provides data reading possibility via M-Bus protocol:

- M-Bus protocol according to EN13757-3 standard
- 2-wire with polarity reversal protection
- Electrical isolation
- Maximum voltage 50 V DC
- Current drawn: one M-Bus load (1.5 mA)
- Primary or secondary addressing
- Baud rate 300/1200/2400/4800/9600 bps (default: 2400 baud rate)
- Battery lifetime min. 10 years (1 D cell)
- Fastest reading interval at battery supply: every 90 seconds (at 9600 b/s, internally protected)
- Fastest reading interval at mains supply: no limits (auto at order or manual if added later)

Radio OMS 868.95 MHz interface

The module can provide data reading via radio module:

- Wireless M-Bus protocol according to EN13757-4
- OMS (open metering system) compatible
- T1 mode (unidirectional)
- Sending interval every 90 seconds (suitable for 'walk by' readings)

Modbus RS-485 module

RS-485 module is Modbus RTU protocol and a serial interface for communication with external devices.

Baud rate	1200, 2400, 4800, 9600(default), 38400, 56000, 57600, 115200 bps
Power supply	Polarity independent connection for power supply – connectors 60 and 61. Voltage 12-24 V AC/DC. Maximum power consumption 2 W max. Typical supply current 50 mA.

Pulse inputs

Number of pulse inputs	2
Measurement units	m ³
Pulse value	configurable by control buttons
Min. pulse time	100 ms
Pulse type	IB by LST EN1434-2
Max. frequency of input pulses	5 Hz
Max. voltage of input pulses	3.6 V

Data logger

Data logger

Daily, weekly and monthly parameter values and errors are recorded in heat meter memory:

Data logger capacity

up to 110 days (3,5 months) – for hourly records.
up to 1461 days (36 last months) - for daily and monthly records.

Retention time of measured integrated parameters even if device is disconnected from power supply not more than 12 years

Power supply

Power supply (one of following depending on meter configuration):

- 1 D-cell battery 3.6 V DC, 19 Ah (ER 34615) lithium battery, life time at least 10 years.
- Mains power supply 230 V AC 50 (+/- 2) Hz.

Display symbols description

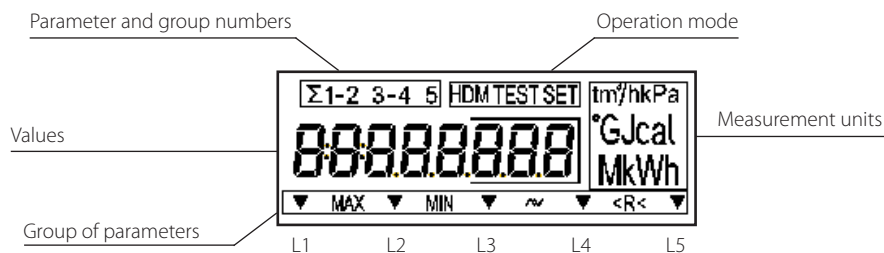

Display menu structure

Parameters shown	Identification symbols				
Integral values (L1)	▼				
	L1	L2	L3	L4	L5
Instantaneous parameters values (L2)		▼			
	L1	L2	L3	L4	L5
Set day parameters and archive data values (L3)			▼		
	L1	L2	L3	L4	L5
Printing reports by standard printer (L4)				▼	
	L1	L2	L3	L4	L5
Configuration settings parameters (L5)					▼
	L1	L2	L3	L4	L5
Parametrization (configuration) mode (SET)			SET		
	L1	L2	L3	L4	L5
Test mode (TEST)			TEST		
	L1	L2	L3	L4	L5

Mounting

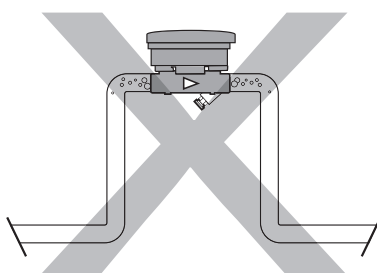

Pipe position: avoid position where air can be collected.

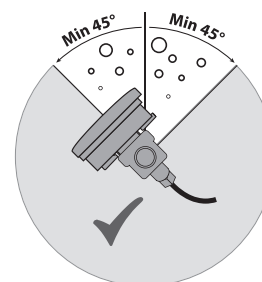

Rotation in pipe axis

Inlet/outlet conditions

In order to maximize performance it is necessary to have straight inlet and outlet flow conditions before and after the flow sensor: 5 × DN on inlet and 3 × DN on outlet of flow sensor.

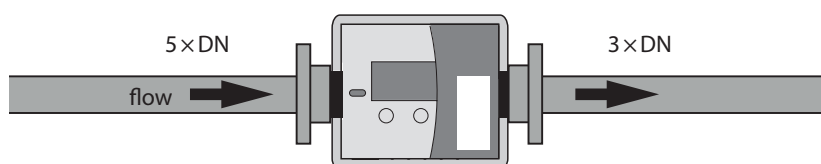

Dimensions

Calculator

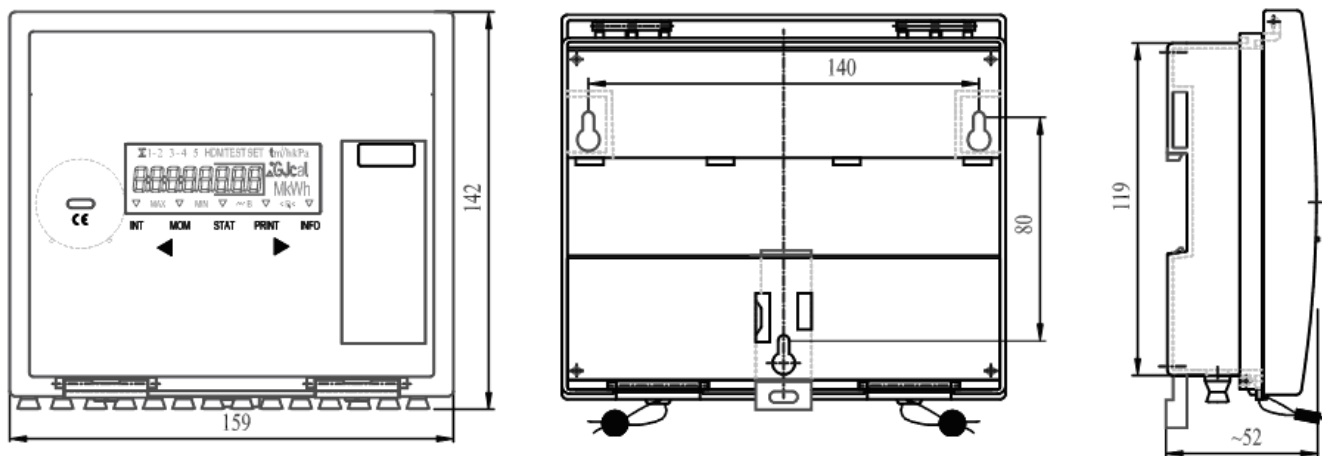

Flow sensor

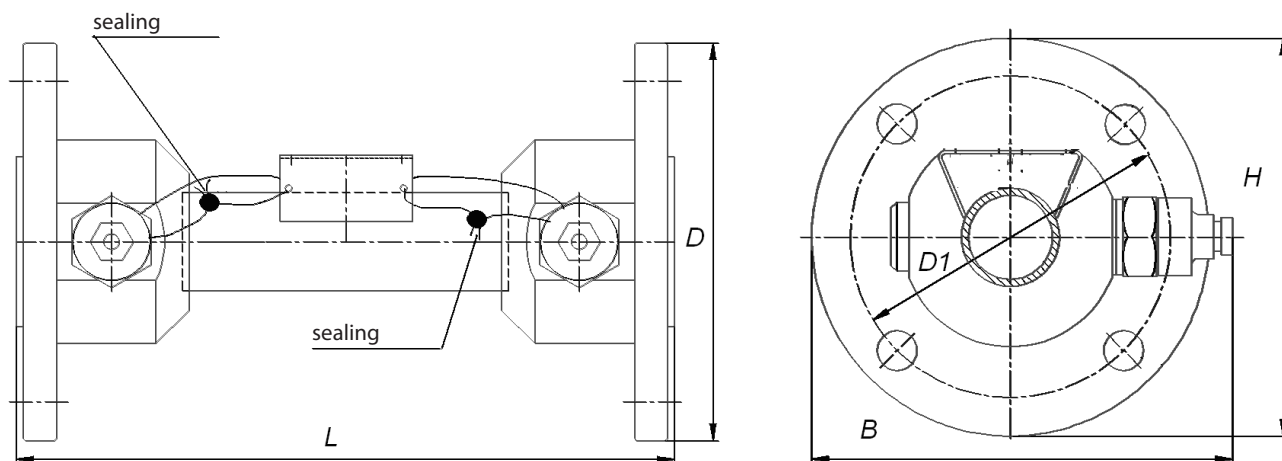

	DN65 / PN16	DN65 / PN25	DN80	DN100
L	300	300	350	350
D	185	185	200	220
H	185	185	200	220
D1	145	145	160	180
B	200	200	215	235
D2	18	18	18	18
holes	4	8	8	8

Temperature sensors

	Installation	Type	Diameter D (mm)	Length L (mm)
	Immersed (direct) or in pocket (indirect)	Pt 500	ø 5.2	45

Sensor pockets

	Type		Brass				Stainless steel			
	Sensor diameter	(mm)	ø 5.2				ø 5.2			
Length	L1 (mm)		47	60	93	128	98	133	168	223
	L (mm)		35	52	85	120	85	120	155	210

ENGINEERING
TOMORROW



Danfoss A/S

Energy Meters • Ulvehavevej 61 • DK-7100 Vejle • Denmark

Phone: +45 7488 8500 • Fax: +45 7488 8501

heating@danfoss.com • www.heating.danfoss.com

Danfoss can accept no responsibility for possible errors in catalogues, brochures and other printed material. Danfoss reserves the right to alter its products without notice. This also applies to products already on order provided that such alterations can be made without subsequential changes being necessary in specifications already agreed.
All trademarks in this material are property of the respective companies. Danfoss and the Danfoss logotype are trademarks of Danfoss A/S. All rights reserved.
